

# SIGMAS-MC

for TRE-G2T, TRE-G3T, TRE-G3TAJ

SIGMAS-MC is a receiver based on our TRIUMPH Technology implemented in our TRIUMPH Chip special designed for machine control applications and useful to increase productivity and improve the quality of your job. For the first time in the GNSS history we offer up to 100 Hz RTK.

216 channels of single or dual frequency GPS, Galileo and GLONASS in a small attractive, sturdy, and watertight box, which contains either TRE-G2T, TRE-G3T or TRE-G3TAJ board.

The on-board power supply on the SIGMAS-MC receiver accepts any voltage from +10 to +30 volts and delivers clean filtered voltage where needed. This eliminates the risk of power contamination (ripples) that can be created when clean power is generated elsewhere and delivered to the board via cables. The SIGMAS-MC receiver also includes GSM module and UHF modem. In addition, the receiver comes with large amount of flash for data storage.

The SIGMAS-MC receiver supports CANopen Slave communication profile according to DS301V4.02. Two M12 CAN connectors providing chaining along with other CANopen devices using conventional cables.

In addition to timing strobe and event marker, the SIGMAS-MC receiver includes the option of complete IRIG timing system.

# SIGMAS-MC

## Standard Configuration

- SIGMAS Receiver (0 MB)
- GPS L1/L2/L5
- GLONASS L1/L2 (G3T, G-3TAJ only)
- RAIM
- RS232 Serial Port (460.8 kbps)
- CAN 2.0 Port
- External GNSS Antenna TNC Female connector

## Optional Feature

- Galileo E1/E5
- Update Rate 1 Hz, 5Hz, 10Hz, 20Hz, 50Hz & 100Hz
- RTK Rate 1 Hz, 5Hz, 10Hz, 20Hz, 50Hz & 100Hz
- Data Recording up to 2048MB
- Multi-Base Code Differential Rover
- Code Differential Base
- Advanced Multipath Reduction
- In-Band Interference Rejection
- Two Event Markers
- Two 1 PPS timing strobes
- External Reference Frequency input
- High speed RS422 serial port (up to 460.8 Kbps)
- Internal UHF Modem
- Internal GSM/GPRS Module
- KFK WAAS/EGNOS (SBAS)
- Mounting Bracket

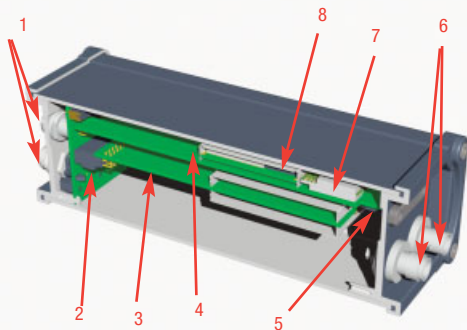

1. Communication and Power Ports
2. GNSS Interconnect Board
3. GNSS Receiver with on-board Memory
4. GNSS Power and Communication Board with on-board SIM card
5. SIM Card Holder
6. External UHF/GSM Antenna Connectors
7. GSM Modem
8. UHF Modem

## Description

Total 216 channels: all-in-view (GPS L1/L2/L5, Galileo E1/E5A, GLONASS L1/L2, SBAS) integrated receiver, rugged aluminum housing

## Tracking Specification

Tracking Channels SIGMAS-MC-G2T	GPS L1/L2/L5 Galileo E1/E5A SBAS
SIGMAS-MC-G3T, G3TAJ	GPS L1/L2/L5 Galileo E1/E5A GLONASS L1/L2 SBAS
Signals Tracked	L1/L2 C/A and P Code & Carrier

## Performance Specifications

Autonomous	<2 m
Static, Fast Static Accuracy	Horizontal: 0.3 cm + 0.5 ppm * base_line_length Vertical: 0.5 cm + 0.5 ppm * base_line_length
Kinematic Accuracy	Horizontal: 1 cm + 1 ppm * base_line_length Vertical: 1.5 cm + 1.5 ppm * base_line_length
RTK (OTF) Accuracy	Horizontal: 1 cm + 1 ppm * base_line_length Vertical: 1.5 cm + 1.5 ppm * base_line_length
DGPS Accuracy	< 0.25 m Post Processing, < 0.5 m Real Time
Cold Start	<35 seconds
Warm Start	<5 seconds
Reacquisition	<1 second

## Power Specification

Power Consumption	
SIGMAS-MC-G2T	3.2 W
SIGMAS-MC-G3T, G3TAJ	4.2 W
External Power Input	1 port
Input Voltage	+10 to +30 volts

## GNSS Antenna Specifications

GNSS Antenna	External
--------------	----------

## Radio Specifications

GSM/GPRS Module	Internal GSM/GPRS quad-band module, GPRS Class 10
UHF Radio Modem	Internal 406-470 MHz radio transceiver, up to 38.4 kbps
Base Power Output	1 Watt

## I/O

External Power port	1 port
Communication Ports	Serial (RS232) up to 460.8 kbps High speed RS422 serial port (up to 460.8 Kbps) CAN (2x M12 connectors for chaining bus)
Other I/O Signals	External Reference Frequency input 2x 1 PPS synchronized 2x Event Marker IRIG

## Memory & Recording

Internal Memory	Up to 2048MB of onboard non-removable memory for data storage
Raw Data Recording	Up to 100 times per second (100Hz)
Data Type	GPS L1/L2/L5/Galileo E1/E5A (G2T); GPS L1/L2/L5/Galileo E1/E5A/ GLONASS L1/L2 (G3T, G3TAJ)

## Data Output

Real time data outputs	RTCM SC104 versions 2.x and 3.x Input/Output
ASCII Output	NMEA 0183 versions 2.x and 3.0 Output
Output Rate	Code and Carrier

## Environmental Specifications

Enclosure	Aluminum extrusion, waterproof IP 67
Operating Temperature	-40° C to +80° C
Storage Temperature	-45° C to +90° C
Humidity	95% non-condensing
Dimensions	W: 132 mm x H: 61 mm x D: 190 mm
Weight	
SIGMAS-MC-G2T	938 g
SIGMAS-MC-G3T, G3TAJ	945 g

Specifications are subject to change without notice.



**JAVAD GNSS**  
www.javad.com