

SIGMAD-MC

for Duo-G2, Duo-G2D

Dual frequency satellite-based two-antenna system SIGMAD-MC is a receiver based on our TRIUMPH Technology implemented in our TRIUMPH Chip special designed for machine control applications and useful to increase productivity and improve the quality of your job.

SIGMAD-MC can also be operated in RTK or DGPS mode from an external base station to provide highly accurate position and velocity.

For the first time in the GNSS history we offer up to 100 Hz RTK. 216 channels of single or dual frequency GPS and Gallileo in a small attractive, sturdy, and watertight box, which contains either Duo-G2 or Duo-G2D board.

The SIGMAD-MC receiver can be used in heading applications and wheeled robot control including steering and path planning. The on-board power supply on the SIGMAD-MC receiver accepts any voltage from +10 to +30 volts and delivers clean filtered voltage where needed. This eliminates the risk of power contamination (ripples) that can be created when clean power is generated elsewhere and delivered to the board via cables. SIGMAD-MC receiver also includes GSM module, UHF modem. In addition, the receiver comes with large amount of flash for data storage.

The SIGMAD-MC receiver supports CANopen Slave communication profile according to DS301V4.02. Two M12 CAN connectors provide chaining along with other CANopen devices using conventional cables.

In addition to timing strobe and event marker, the SIGMAD-MC receiver includes the option of complete IRIG timing system.

SIGMAD-MC

Standard Configuration

- SIGMAD Receiver (0 MB)
- GPS L1/L2
- Galileo E1
- RAIM
- RS232 Serial Port (460.8 kbps)
- CAN 2.0 Port
- 2x External GNSS Antenna TNC Female connector

Optional Feature

- Update Rate 1Hz, 5Hz, 10Hz, 20Hz, 50Hz & 100Hz
- RTK Rate 1Hz, 5Hz, 10Hz, 20Hz, 50Hz & 100Hz
- Data Recording up to 2048MB
- Multi-Base Code Differential Rover
- Code Differential Base
- Advanced Multipath Reduction
- In-Band Interference Rejection
- Two Event Markers
- Two 1 PPS timing strobes
- High speed RS422 serial port (up to 460.8 Kbps)
- Internal UHF Modem
- Internal GSM/GPRS Module
- KFK WAAS/EGNOS (SBAS)
- Mounting Bracket

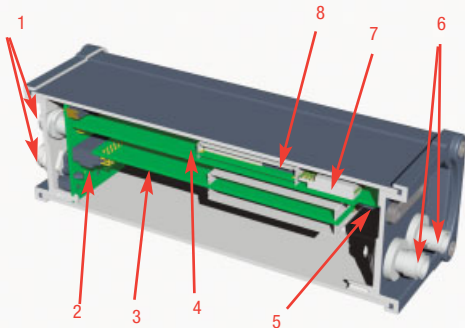

1. Communication and Power Ports
2. GNSS Interconnect Board
3. GNSS Receiver with on-board Memory
4. GNSS Power and Communication Board with on-board SIM card
5. SIM Card Holder
6. External UHF/GSM Antenna Connectors
7. GSM Modem
8. UHF Modem

Description

Total 216 channels: all-in-view (GPS L1/L2, Galileo E1, SBAS) integrated receiver, rugged aluminum housing

Tracking Specification

Tracking Channels	
SIGMAD-MC-G2	2x (GPS L1, 2x Galileo E1, SBAS)
SIGMAD-MC-G2D	2x (GPS L1/L2, 2x Galileo E1, SBAS)
Signals Tracked	L1/L2 C/A and P Code & Carrier

Performance Specifications

Autonomous	<2 m
Static, Fast Static Accuracy	Horizontal: 0.3 cm + 0.5 ppm * base_line_length Vertical: 0.5 cm + 0.5 ppm * base_line_length
Kinematic Accuracy	Horizontal: 1 cm + 1 ppm * base_line_length Vertical: 1.5 cm + 1.5 ppm * base_line_length
RTK (OTF) Accuracy	Horizontal: 1 cm + 1 ppm * base_line_length Vertical: 1.5 cm + 1.5 ppm * base_line_length
DGPS Accuracy	< 0.25 m Post Processing, < 0.5 m Real Time
Real time attitude accuracy	Heading ~ 0.004/L [rad] RMS, where L is the antenna separation in [m]
Cold Start	<35 seconds
Warm Start	<5 seconds
Reacquisition	<1 second

Power Specification

Power Consumption	3.7 W
External Power Input	1 port
Input Voltage	+10 to +30 volts

GNSS Antenna Specifications

GNSS Antenna	External
--------------	----------

Radio Specifications

GSM/GPRS Module	Internal GSM/GPRS quad-band module, GPRS Class 10
UHF Radio Modem	Internal 406-470 MHz radio transceiver, up to 38.4k bps
Base Power Output	1 Watt

I/O

External Power port	1 port
Communication Ports	Serial (RS232) up to 460.8 kbps High speed RS422 serial port (up to 460.8 Kbps) CAN (2x M12 connectors for chaining bus) External Reference Frequency input 2x 1 PPS synchronized 2x Event Marker IRIG
Other I/O Signals	

Memory & Recording

Internal Memory	Up to 2048MB of onboard non-removable memory for data storage
Raw Data Recording	Up to 100 times per second (100Hz)
Data Type	Code and Carrier from GPS L1/Galileo E1 (G2) GPS L1/L2, 2x Galileo E1 (G2D)

Data Output

Real time data outputs	RTCM SC104 versions 2.x and 3.x Input/Output
ASCII Output	NMEA 0183 versions 2.x and 3.0 Output
Output Rate	Code and Carrier

Environmental Specifications

Enclosure	Aluminum extrusion, waterproof IP 67
Operating Temperature	-40° C to +80° C
Storage Temperature	-45° C to +90° C
Humidity	95% non-condensing
Dimensions	W: 132 mm x H: 61 mm x D: 190 mm
Weight	958 g

Specifications are subject to change without notice.



JAVAD GNSS
www.javad.com

